

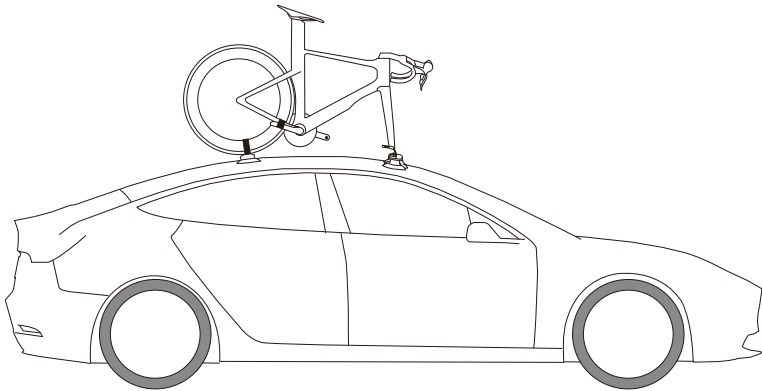

Owner's Manual

Model Elite & Pro Bike Rack Series











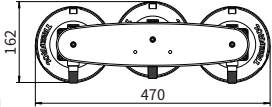

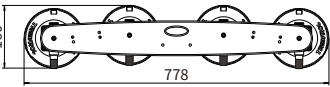
IMPORTANT INSTRUCTIONS
Read This Before Using TreeFrog Products

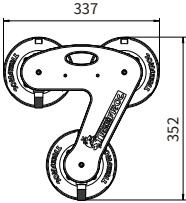
WARNING:

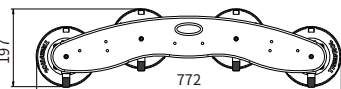
Bikes or racks falling in the road can cause serious accidents resulting in bodily injury - so do not use the rack on any vehicle on which it can not be properly mounted as described in this instruction manual.

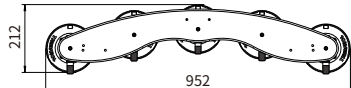
- All the TreeFrog vacuum mounts must be fully mounted completely to the metal, glass, or fibreglass surface - never attached to rubber or plastic moldings.
- Only the TreeFrog rubber vacuum mounts should be attached to the vehicle. Never use the rack on trailers or on the front of vehicles.
- Never carry more weight on the rack than the bike rack's maximum loading capacity. Car tail lights must remain visible.
- Drive conservatively, especially over bumps. Never use off road.
- Do not use if any part of the rack is damaged, worn, or missing. Contact to www.treefrog racks.com for replacement parts.

<p style="text-align: center;">Load Limited</p> <p>Models</p>	 <p style="text-align: center;">DO NOT EXCEED RACK WEIGHT LIMITS!</p>
 <p>Elite 1</p>	<p style="text-align: center;">12kg. (26 lbs)/bike</p>  <p>No mountain and e-bike!!! only road, gravel, triathlon, cyclocross bikes</p>
 <p>Elite 2</p>	<p style="text-align: center;">12kg. (26 lbs)/bike, total 22 kg</p>  <p>No mountain and e-bike!!! only road, gravel, triathlon, cyclocross bikes</p>
 <p>Pro 1</p>	<p style="text-align: center;">20kg. (44 lbs)/bike</p>  <p>No e-bike!!!</p>
 <p>Pro 2</p>	<p style="text-align: center;">20kg. (44 lbs)/bike, total 40kg</p>  <p>1 e-bike (up to 27kg), placed in the middle position</p>
 <p>Pro 3</p>	<p style="text-align: center;">20kg. (44 lbs)/bike, total 60kg</p>  <p>Max. 2 e-bikes (up to 54kg)</p>

Safety first

- Clean the car mounting surface with the TreeFrog towel and the rubber vacuum pads with clean water before mounting the rack to the vehicle.
- Make sure that the rack's rubber vacuum pads are fully mounted to the surface, and all the vacuum pumps fully seated.
- Check the vacuum pump white indicator band during use.
- After you mounted your rack on your vehicle, and less than **3 hours** later the sealing is not holding vacuum and the white safety indicator band is becoming visible, do not use the rack. Do the maintenance and test the bike rack for **24 hours** before using it again!
- Lube the vacuum pumps regularly.
- Do not use if the indicator band is exposed on any of your pumps.
- Do not exceed the posted speed limit. Speed limits must under no circumstances exceed **130 km/h**. Do not drive over speed bumps faster than **25 km/h**.
- Regularly inspect screws, nuts and bolts after every couple of use and retighten if necessary.
- Make sure the fork mount quick release is fully clamped and the fork is secure.
- TreeFrog rack system allows you to attach the rack to the sunroof, but once the rack being installed, the sunroof must not be opened.
- To avoid damage to the rear door or trunk, when the rack has been placed at the back of the vehicle, please open the trunk or the rear door with care.
- Only the TreeFrog rubber vacuum pads should contact the vehicle.
- Use the **protective cover** when the rack is not in use.

CAUTION:

- Use TreeFrog racks only in accordance with local motor vehicle and traffic regulations.
- Install rack and load bicycles only at a safe distance away from moving traffic.
- Do not place a TreeFrog rack on the side of the vehicle, and do not mount bicycles sideways.
- Make sure that the rack and bicycles are kept at a safe distance from road and hot exhaust.
- Always remove the rack when not in use, and properly store it with its **protective cover**.

RESPONSIBILITY

- You must check all the TreeFrog vacuum pumps' white safety indicator bands on the rack before entering your car to start your journey.
- During your journey, check white indicator bands visually when you stop at gas stations or any resting places.
- The vacuum pumps' white safety bands will indicate if the vacuum cups are not maintaining vacuum, and will extend out and become visible upon loss of vacuum.
- If you see the pump's white safety indicator band, the vacuum level must be adjusted so that the white safety indicator is not visible before continuing on your journey.

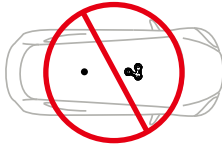
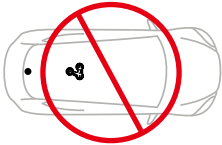
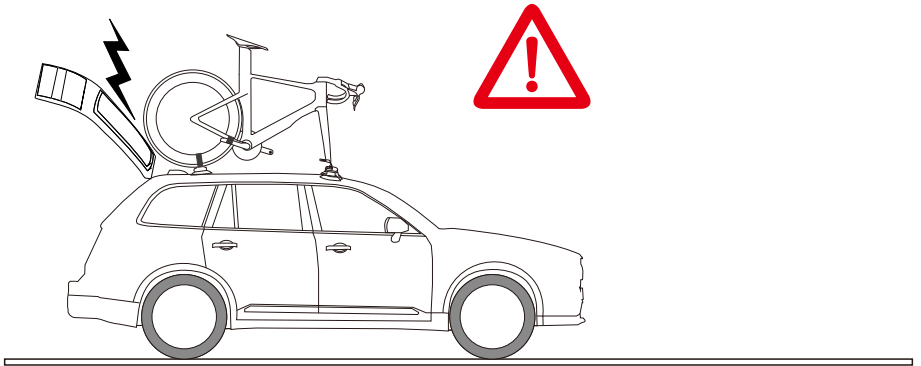
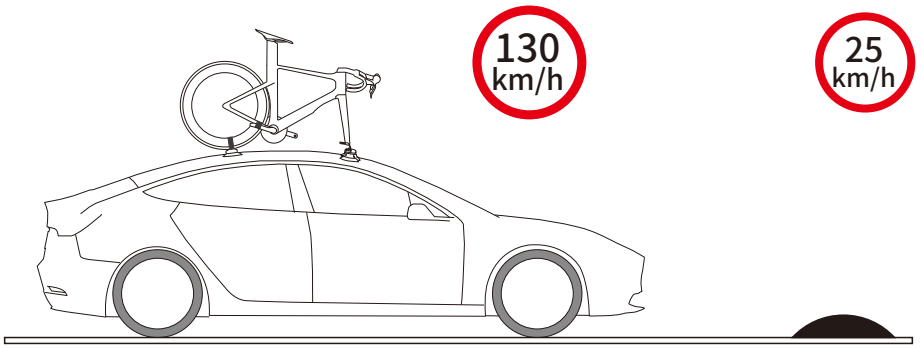

The Rear Wheel Strap
Should be mounted on the
metal part of the rear hatch.



Caution:

Some panoramic sunroof glass may not be strong enough. In an abundance of caution we are recommending that Panoramic Sunroof Car owners using TreeFrog bike racks mount the racks on their cars so that the Rear Wheel Strap lands on the metal part of the rear hatch (see drawings above). Do not hit, punch, or slam the rack or Rear Wheel Strap to create a seal when installing. Place the rack in position and press down just firmly enough to create a seal when pumping.

ASSEMBLY

- All the TreeFrog racks need minor assembly prior to use.
- The bike racks that come with fork mounts are not attached to the bike rack board (except the Pro 3 bike rack).
- Place the fork mount over the mounting holes in the board and secure it with the hardware and the tool set that came with the rack.
- Check the fork mount when you place your bike on the rack for the first time and make sure the fork mount does not move when pressure is applied.
- NOTE - There are 2 curved holes on the Model Elite/Pro 2 and Pro 3 decks that allow you flexibility in positioning the fork mounts to avoid wider handlebars hitting each other.

What's in the box:

Model Elite 1

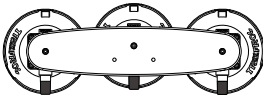

x1

FMU09/12x100

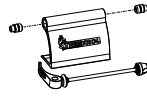

x1



x1



x1

Model Elite 2

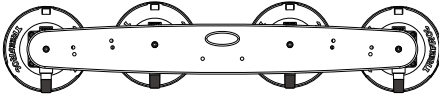

x1

FMU09/12x100

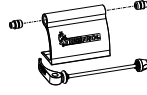

x2



x2



x1

Model Pro 1

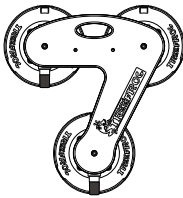

x1

FMU09/15x100

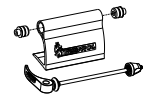

x1



x1



x1

Model Pro 2

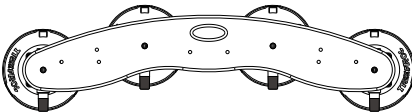

x1

FMU09/15x100

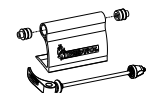

x2



x2



x1

Model Pro 3

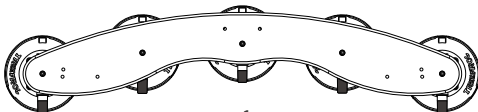

x1

FMU09/15x100

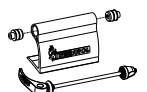

x3



x3



x1

Model Elite 1

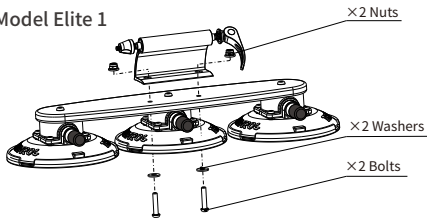

Model Elite 2

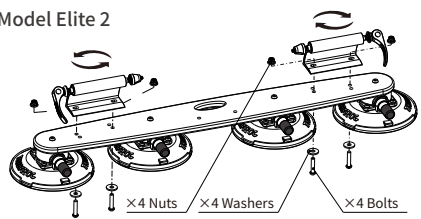

Model Pro 1

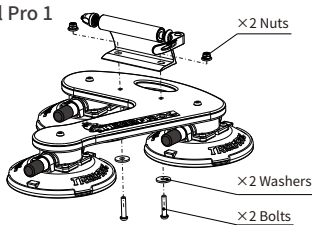

Model Pro 2

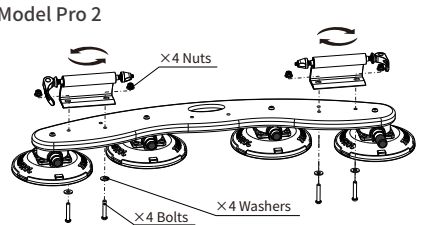

Model Pro 3

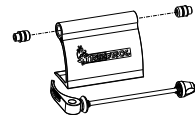
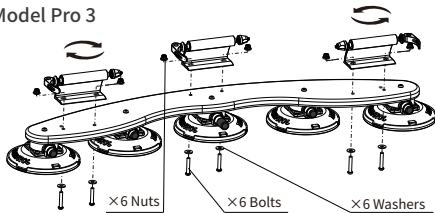

Universal Fork Mount QR09/12x100mm
 Pull the quick release and plunger out, the fork mount can be applied to Thru Axle 12x100mm
 Same as Universal Fork Mount QR09/15x100mm

MOUNTING TREEFROG RACK

- All the bike rack decks with the fork mounts, **MUST** be placed at the front of the car with the rear wheel holder(s) at the back. **NEVER** mount the bike rack sideways, and **NEVER** mount the rear wheel holder at the front!
- Always position the bike rack close to the front edge of the roof, or to the front or back windshield and close to the side of the roof, where the roof has more internal support. Some cars' metal roofs may not be strong enough in the middle to support bikes that are close to the weight limit.
- All TreeFrog bike rack decks are designed to follow the curvature of any car's roof. We recommend you first attach one of the cups to one side of the car and secure the first and second vacuum cups, and then go to the other side and use the deck as leverage to attach the next vacuum cup until the last one has been secured.
- Clean the surface where the rack's vacuum cup will be mounted with the TreeFrog soft rag that came with the rack. Then, remove the protective cover, and moisten the bottom edge of the cups with water only before you mount the rack. Next press the vacuum down to make sure the edge of the cup is connected and start pumping the air out until the white safety indicator band is no longer visible. Continue this process until all vacuum cups are secure.
- If the plunger will not stay seated and the pump's white safety indicator band becomes visible immediately after pumping, inspect the rubber vacuum pad for damage or clean the mounting surface and vacuum cup again. If the problem isn't solved after these basic steps, please do basic maintenance on the pump using the silicone lube that was supplied with the rack. **DO NOT** use your rack without solving the problem!

Where to Attach

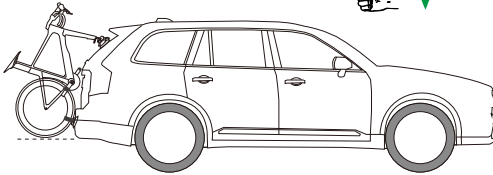
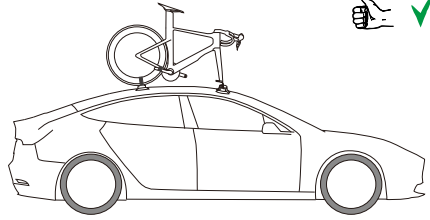
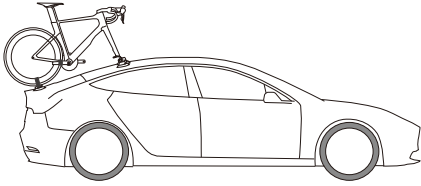

For hatchback/SUV/van mounting, make sure the bicycle's rear wheel does not hang lower than the bottom of the vehicle's bumper.

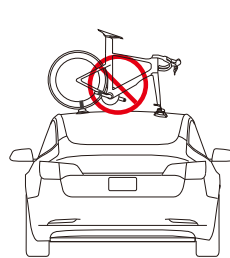
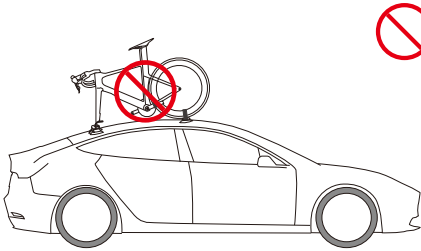

How to pump



1. Press the vacuum down to make sure the edge of the cup is connected.
2. Pumping the air out until the white safety indicator band is no longer visible.

Full Power



Indicator band exposed:
time to re-pump



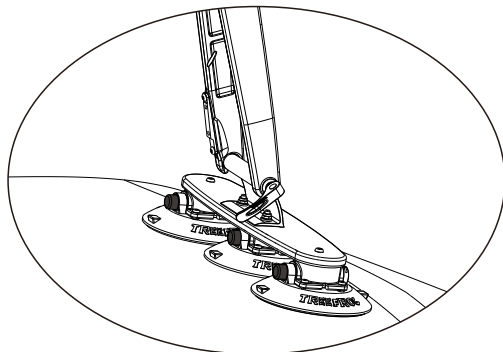
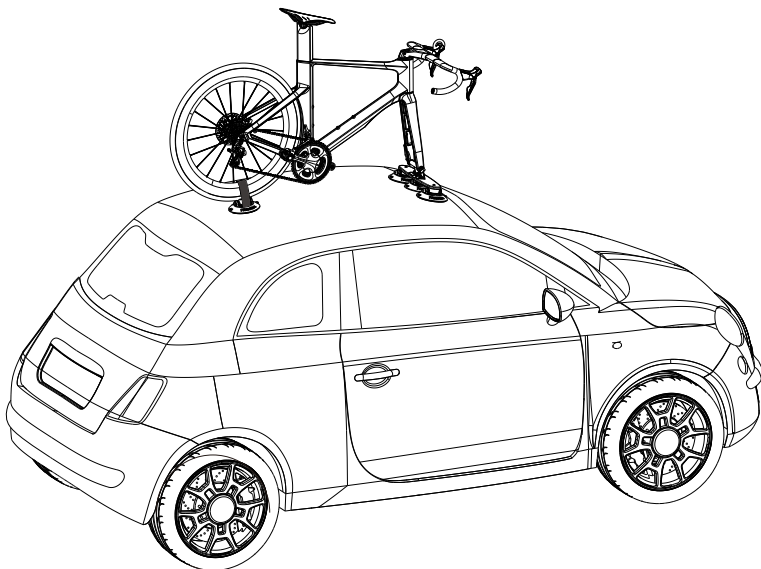

- ① Mount the bike deck to the car and secure the fork to the fork mount

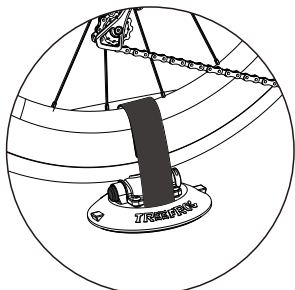

- ② Place the rear wheel holder under the rear tire, and secure the wheel with the velcro

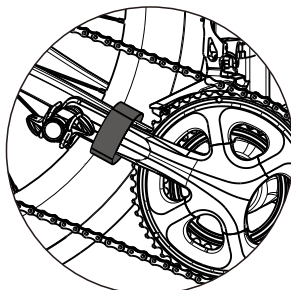

- ③ Secure the crank arm to the frame with the crank velcro

- Attaching a rack to a sunroof is done at your own risk, and we strongly recommend that you test the strength and suitability of your sunroof first. **DO NOT** open the sunroof if the rack or the rear wheel holder vacuum cups are too close to the sunroof or if any vacuum cup has been attached to the sunroof.
- After you mount the rack to the surface, please remove the bike's front wheel. Place the fork dropouts onto the TreeFrog fork mount and secure it with your thru axle/TreeFrog quick release by clamping it the same way you would your front wheel. Before you secure the rear wheel, make sure the fork is fully secure. Then, placing the rear wheel holder under the rear tire, secure the rear wheel with the Velcro/ladder strap.
- You are not required to use the Rear Wheel Strap when hanging your bicycle from the back glass .
- All TreeFrog products can be used in rain, low temperatures and at high altitudes.

CAUTION:

- **Never put water on the vacuum cups when the weather temperature could go below 0 Celsius!**
- In low temperatures the rubber vacuum pads may become stiffer. When removing your rack, please store it at room temperature (or at least **above 15 Celsius**) before remounting it.
- **During winter make sure the surface is dry and free of ice before mounting the rack!**

DEMOUNTING TREEFROG RACK

- To remove your bike, first open the Velcro or ladder strap and make sure both ends are fully separated from each other before you open the quick release and un clamp the fork.
- After you have removed your bike, simply lift up the vacuum cup anywhere around its edge to break the vacuum seal.
- When you have removed all the vacuum cups, please put the protective cover back.

NOTE - Never place or store the rack on the rubber vacuum cups without protective covers!

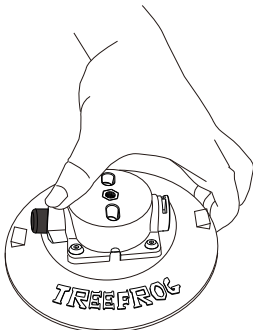

How to break the vacuum seal

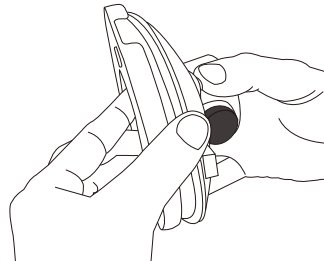

Always put the protective cover back when not in use

REGULAR CHECKING AND PUMP MAINTENANCE

- Keep the vacuum cups clean, and always store them with the protective green covers. Please use the soft TreeFrog rag that came with the product and clean the vacuum pads with water before each use. If you observe any dirt on the vacuum pad, please remove it with soapy water and the soft TreeFrog rag.
- Please check all the screws and hardware regularly to make sure they haven't come loose during previous use. Tighten the housing to the vacuum pad, and the deck to the vacuum cup screws, and the fork mount screws and bolts if necessary. Regardless of how many times the rack has been used, you must perform maintenance on the vacuum pumps if any of the pump's white safety bands appear less than 3 hours after the vacuum cup has been mounted and pumped to full strength. We also recommend, after the rack not being used for a long period of time, or before the cycling season starts, and you would like to use the rack regularly again, please test the rack on your car and check how long the vacuum pumps hold a seal before the white safety band appears. Before cycling season starts, that is the best time to perform maintenance and get your rack ready for the season!

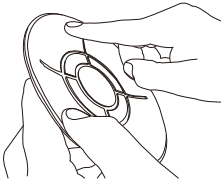

Check to ensure there is no scratch on the edge of the vacuum cup.

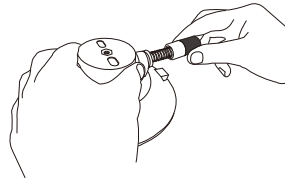

Pull the plunger straight out from the pump cylinder.

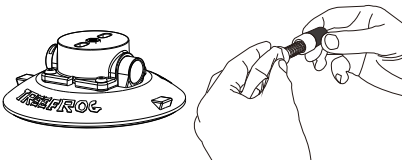

Clean the inside of the cylinder and the plunger with a lightly wet paper towel

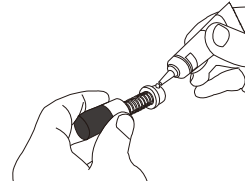

Re-lube the rubber O-ring with a thin layer of silicone gel



Push the plunger back into the cylinder and pump several times to ensure the pump move back and forth freely and smoothly

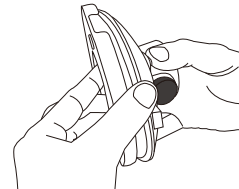

Always put the protective cover back when not in use

You must perform maintenance on the vacuum pumps if one of the pump's white safety bands appear less than 3 hours

- To perform maintenance on the pump, simply grab the pump's white indicator and pull the plunger straight out from the cylinder. Clean the cylinder inside with a lightly wet paper towel. After you have cleaned the cylinder inside, please wipe it with a dry paper towel. Next, clean the head of the plunger and the rubber O-ring. You must re-lube the rubber O-ring with a thin layer of silicone gel that came with the rack, and push the plunger back to the cylinder. After you have finished these maintenance steps, the pump should move back and forth freely and smoothly. Please test all the rack's vacum cups by placing them on your car or any glass surface for the next 20 -24 hours. If the white safety band does not appear, you can start to use your rack. If the white safety band appears, please repeat the maintenance steps until the pump performs well.

NOTE - Any damaged hardware, pumps or vacuum pads must be replaced. All replacement parts are available at www.treefrog racks.com

- We recommend to return the rack to your local dealer, so they can perform the maintenance for you.

-We are also offering free maintenance to all TreeFrog customers. Simply ship the product back to our service center and we charge only for the necessary replacement parts.

To take advantage of this free maintenance option, please email us at iinfo@treefrog racks.com

Tutor maintenance videos also available at www.treefrog racks.com

GUARANTEE

The Guarantee covers any defect or damage affecting your TreeFrog product for 2 years following the date of the purchase of the first customer. Guarantee gives you specific legal rights. It does not affect any statutory rights that you have as a customer of a defective product. Guarantee does not cover defects resulting from conditions beyond TreeFrog's control. Including but not limited to misuse, overloading or failure to assemble, mount or use the product or it's accessories in accordance with the TreeFrog's witten instructions, guidelines and safety specifications. Nor does it cover any damage to the user's vehicle, electronic devices, cargo, or to any other person or property.

TREEFROG DISTRIBUTORS RESERVES THE RIGHT TO:

- Repair the item falling under the terms of the guarantee
- Replace the item if the damage or defect cannot be repaired
- Offer a similar product of comparable value, or refund the price paid, if the original product can not be replaced with the same model

WARRANTY

The TreeFrog warranty applies to products and accessories produced by TreeFrog and sold to the original customer under the brand name TreeFrog. The warranty covers defects in materials or workmanship and, depending on the type of product, applies up to 2 years from the date of the original retail purchase. Subject to the limitations and exclusions described in this warranty, TreeFrog remedies defects in materials or workmanship during the warranty period by repairing or replacing the defective component(s) without charge for parts or labour.

**Accessories and other products please find at: www.treefrog racks.com
or contact the local dealers.**



TREEFROG Sports Equipment Co., Ltd.

 www.treefrogracks.com

 info@treefrogracks.com